

# ZPT15/17/20 /25 Rotary Tablet Pressing Machine



01. Stainless steel 304 main machine housing. The parts that contact with the powder are made of stainless steel.
02. No-handwheel operating system. PLC touch screen controller.
03. Special oil leakproof and dust proof devices install in die holes.
04. Powder force feeding device .
05. Rejection in bulk.
06. Sensor system – alarming first and then stopping machine when any one is happened as following situation:
  - A. Without powder or pellet
  - B. Open the plastic door
  - C. Motor of dust collector is overload
  - D. Inverter is in trouble
  - E. Lack of lubrication
07. Electrical control system.
  - A. Rapidity display.
  - B. Alarm display.
  - C. Main motor state display
08. English and Chinese operation system.
09. Spare parts one set, tool kit & operation manual.
10. Wooden case package (export standard).
11. Tablet weight control, single rejection function for R&D ,for your choice.





## 工业吸尘器 DUST COLLECTOR

### 主要技术参数 Main Technical Data

型号 Model	XGB110	XGB220	XGB300
风量 (立方米/小时) Air Volume(m <sup>3</sup> /h)	135	210	210
电源要求 power	380V/50Hz 1.1KW	380V/50Hz 2.2KW	380V/50Hz 3.0KW
外形尺寸 (毫米) Size L X W X H(mm)	700×450×1200	850×440×1140	850×440×1140
重量 (公斤) Weight(kg)	55	80	80

注：若因任何技术改进而参数改变，恕不另行通知。  
Re: No additional information noted if there are any changed caused by the technical development.



## 工业脉冲吸尘器 PULSE-JET VACUUM CLEANER

### 性能优势

该机采用聚酯滤筒过滤立式结构，自动脉冲喷涂清灰装置。含有粉尘的空气从进风口吸入，经过滤筒过滤，粉尘收集到集粉箱内，清洁空气由风机排出。

该机特点是：排风量大，吸力强劲；噪音低，运行平稳可靠；滤筒滤料高强度，耐酸碱，可用水反复清洗，且过滤面积大，运行阻力小，过滤效率高；该机材质全部采用不锈钢，清洗方便。该机对比重大，中，较轻及非纤维粉尘均有良好的吸尘效果，并可以回收粉尘。

### Performance Advantage

This machine is a polyester filter cartridge type with automatic pulse-jet cleaning system. It absorb the dust through filtering, the dust will be collected in to the powder box, and the clean air blow-out.

The feature of this machine is :strong suction capacity, low noise, easily to operate, maintain and clean, high strength, acid & alkali resistant and washable filter cartridge; large filtering area, low resistance, high filter efficiency; this machine material all stainless steel, easy for washing. This machine is fit for heavy, middle, light and non-fiber dust, and can also recycle the dust.

### 主要技术参数 Main Technical Data

型号 Model	MCX1000	MCX1500
风量 (立方米/小时) Air Volume(m <sup>3</sup> /h)	1000	1500
额定压力 Wrod Pressure(Pa)	4600	6860
过滤面积 Fitter Area(m <sup>2</sup> )	6.5	11
电源要求 power	380V/50Hz 2.2KW	380V/50Hz 2.2KW
外形尺寸 (毫米) Size L X W X H(mm)	480×500×1450	590×610×1780
重量 (公斤) Weight(kg)	105	135

注：若因任何技术改进而参数改变，恕不另行通知。  
Re: No additional information noted if there are any changed caused by the technical development.





## 筛片机

### MULTI-LAYER DEDUSTER

#### 主要技术参数 Main Technical Data

型号 Model	SP-300
生产效率 (片/小时) Output Efficiency(tablet/h)	0-750000(Φ8)
除尘距离 (米) The Gumming Distance of Table(m)	3
电源要求Power	220V/50Hz 0.6A
空载噪声值 (分贝) Idle load noise dB(A)	≤60(dB)
外形尺寸 (毫米) Diameter Height(mm)	Φ350×800
重量 (公斤) Weight ( Kg )	38

注: 若因任何技术改进而参数改变, 恕不另行通知。  
 Re: No additional information noted if there are any changed caused by the technical development.

## 上旋式多层筛片机

### SPIRAL DEDUSTER



#### 性能优势

SSP上旋式多层筛片机是吸取国外先进技术研制成功的, 具有筛片弹推升和片剂除尘的双重功能。

其优点是冲剂除尘路程长, 药片自动翻面磨光, 除尘效果好但不损伤片剂。同时可作为需要自动除尘的片状、块状、粒状固体制剂产品的输送设备, 完全符合“GMP”要求。该机在设计过程中采用多项新颖设计, 从而保证了生产过程中更加安全、规范。

#### Performance Advantage

SSP spiral multi-layer deduster was brought on the basis of international technology, it has double functions: tablet loading and tablet dedustering. Its advantage long-road tablet dedustering, automatic tablet purging and polishing, effective deduster and do not damage the tablet. At the same time, it can serve as a transmit instrument. Totally meet with the standard of "GMP" requirement. This machine adopt new structure, and guarantee the safety and stability.

#### 主要技术参数 Main Technical Data

型号 Model	SSP-230
生产效率 (片/小时) Output Efficiency(tablet/h)	0-100000(Φ8)
除尘距离 (米) The Gumming Distance of Table(m)	6.2
电源要求Power	220V/50Hz 1.5A
压缩空气 (公斤) Compressed Air(kg)	0.1m <sup>3</sup> /min-0.1MPa
真空吸尘 Vacuum Dust Collect	2.5m <sup>3</sup> /min-0.1MPa
空载噪声值 (分贝) Idle load noise dB(A)	<60
外形尺寸 (毫米) Size L X W X H(mm)	360×450×1200
重量 (公斤) Weight(KG)	70

注: 若因任何技术改进而参数改变, 恕不另行通知。  
 Re: No additional information noted if there are any changed caused by the technical development.

## 真空上料机 VACUUM FEEDER



### 性能优势

本产品可消除物料静电，密封传输粉体无泄露，利于环境保护，彻底解决粉粒分层问题，可编程自动化控制，简单快捷易于操作。  
低耗能，低噪音，无振动，运行费用低，轻便易安装，易拆卸，易清理，无死角。  
关键部件均采用国外知名品牌，适用于多种制药设备的上料及输送，完全符合GMP标准。

### Performance Advantage

The product can remove material static, transmit the powder leakage, is beneficial for the environment cleaning resolve the powder delaminate problem completely. Programmable automatic control, easy and convenient for operator.  
Low cost, low noise, no vibration, the running cost is low. Easy for installation, unloading and cleaning.  
Main parts adopt the foreign famous brand. Applied to the feeding and transporting of pharmaceutical machine. Fully meet with GMP requirements.

### 主要技术参数 Main Technical Data

型号 Model	ZKSS-700	ZKSS-1300
输送能力(公斤/时) Max feeding ability (kg/h)	700	1300
压缩空气压力 Compressed air pressure	0.55 MPa	0.6 MPa
最大耗气量 Max air exhaustion	300-376 L/Min	600-752 L/Min
最大提升高度 Max loading height	10 m	12 m
最大真空度 Max vacuum	92 KPa	92 KPa
空载噪声值(分贝) Idle load noise dB(A)	<60dB(A)	<65dB(A)
外形尺寸(毫米) Diameter Height(mm)	Φ160×740	Φ160×820
重量(公斤) Weight (kg)	14.5	16.5

注：若因任何技术改进而参数改变，恕不另行通知。  
No additional information noted if there are any changes caused by the technical development.

## 高质量的模具 HIGH QUALITY MOULD

本公司生产的模具是选用特种合金钢，经特殊的热处理工艺，电脑设计模具图形，由高精密的数控机床加工而成。其高硬度，高韧性及高耐磨性的特点不仅适用于国内各种高低速机型，而且能与各类进口压片机配套使用。  
本产品精度高，互换性强，是各制药业及食品、保健品业提高效率降低成本的最佳选择。

The mould is precisely processed with special alloy steel, drawing is designed by computer, manufactured by high and precise numerical control machine. Its special feature is high hardness, high malleability and the high abrasion. It is not only used for domestic high-speed, lower-speed tablet pressing machine, but also applying to any kind of imported tablet pressing machine.

The mould is precise and with high interchangeability, which is an ideal choice for pharmaceutical and food health factory, will definitely increase your efficiency at the same time decrease the cost.



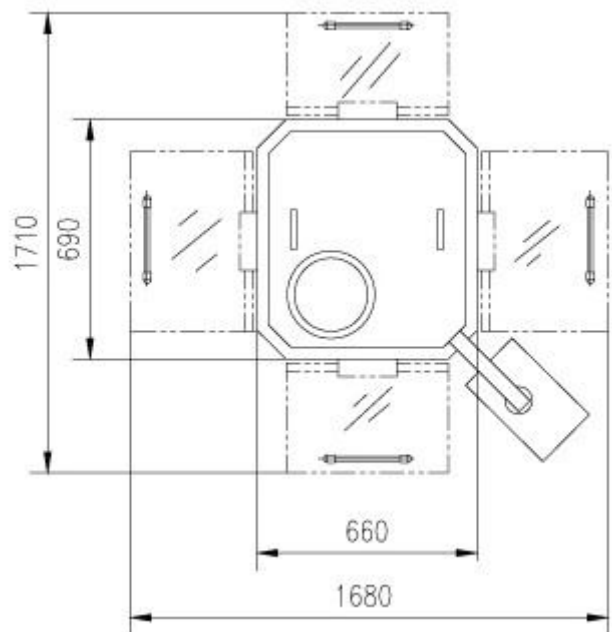
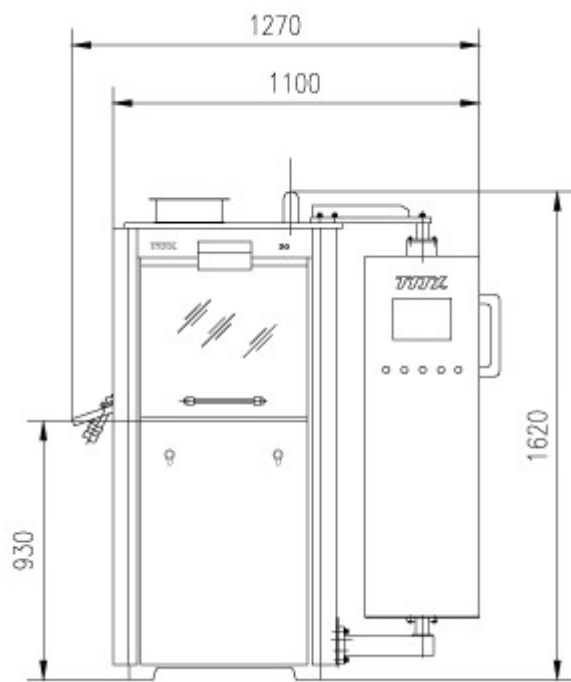
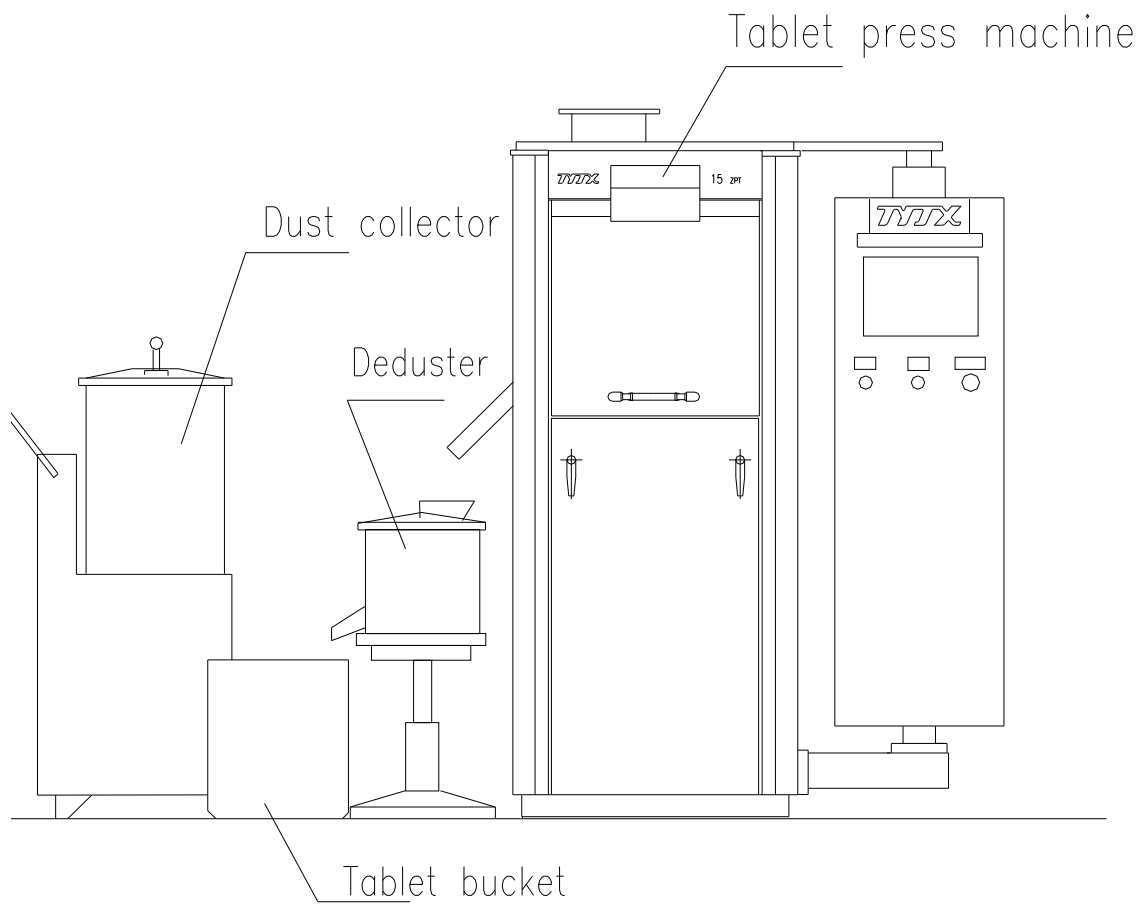

## Technical parameters

No	Name	Model			
		ZPT15 D tooling	ZPT17 B tooling	ZPT20 BBtooling	ZPT25 BBStooling
1	Number of dies (EU)	15	17	20	25
2	Maximum diameter of tablet pressed (mm)	25	16	13	11
3	Maximum diameter of oblong tablet (mm)	25	18	16	/
4	Maximum pre-pressure (KN)	12			
5	Maximum main pressure (KN)	100	80	80	80
6	Maximum filling depth (mm)	20	16	16	16
7	Maximum production capacity (t/h) theoretical yield	70000	80000	95000	118000
8	Power of main motor (KW)	5.5			
9	Outer specification of machine (mm)	660×690×1620			
10	Net weight of machine (kg)	675			

The actual output depends on the actual powder, machine adjustment, operator and related environment .



## Key components

PLC	Japan OMRON/ SIEMENS
Inverter	Delta/ SIEMENS
Main motor	Germany SIEMENS
Touch screen	Taiwan EVIEW/ SIEMENS
Dry oil and thin oil lubrication	BIJUR of Sino-Foreign join venture
Short-circuit protector	France Schneider
Approach sensor	Japan OMRON
Contactor	France Schneider
Worm reducer	Zhejiang Wuma company
Connection terminal	Germany phoenix
Other protection switches	Japan OMRON
Emergency stop push-button, key, switch	France Schneider

**We could change some key components to world famous brand according to clients request.**

ZPT15 TABLET PRESS MACHINE PACKING LIST

	Name	Quantity
Spare parts	Lower cam guide rail	1 piece
	Intercept oil ring	20 piece
	Sealing ring	5 pieces
	Middle punch compact subassembly	5 pieces
	Damp dowel	5 pieces
	Turret spring	5 pieces
	Multiple-block-joint	5 pieces
	Screw	5 pieces
Tools	Knife straight edge	1 piece
	'-' Screwdriver	1 piece
	'+' Screwdriver	1 piece
	Adjustable spanner	1 piece
	Allen wrench	1 piece
	Feeler gauge	1 piece
	Scrubbing brush	1 piece
	Dust ring fixed sleeve	1 piece
	Door key	1 piece
	Hand shank assembly	1 piece
	Die pad	1 piece
	Die hole hairbrush	1 piece
	Die wrench	1 piece
	Shock pad	4 pieces
	Dust ring installing rod	1 piece
Locating sleeve	1 piece	

## Price and Payment

Machine name	Price		
ZPT20 tablet pressing machine  Contacting product parts 316L, other related parts SS304,  With 20 sets round tablet punches and tooling	36500		
XGB dust collector	Free		
(Following accessories for your choice)			
SP300 Spiral deduster	2250	Regular punch&die	125/SET
Irregular punch&die	80/SET	Agreement of exchange rate	6.0
<p>Delivery :</p> <p>50 working days from the receipt of down payment and signed drawing of products to be operated on the machine. (The actual delivery time depend on your order)</p>			
<p>Payment terms</p> <p>30% down payment by telegraphic transfer, 70% balance by T/T before shipment Validity of this quotation: 30 days</p>			
<p>We need to know the client's tablet drawings to recommend the punch tooling amount and final discount price.</p>			

## After-sale service

After our machine arrives at your company, please send us invitation for our technician to your country do installation and training.

(There are 15 technicians have passports in TYJX Ltd.)

The foreign clients should arrange and pay for the round-trip tickets ,accommodation expenses for after-service people.

One set spare part for machine is free.

One year warranty.

